

**0.6 A OUTPUT CURRENT, HIGH CMR
8-PIN DIP IGBT GATE DRIVE PHOTOCOUPLER** –NEPOC Series–

DESCRIPTION

The PS9553, PS9553L1, PS9553L2 and PS9553L3 are optically coupled isolators containing a GaAlAs LED on the input side and a photo diode, a signal processing circuit and a power output transistor on the output side on one chip.

The PS9553 Series is designed specifically for high common mode transient immunity (CMR) and high switching speed. It is suitable for driving IGBTs and MOS FETs.

The PS9553 Series is in a plastic DIP (Dual In-line Package).

The PS9553L1 is lead bending type for long creepage distance.

The PS9553L2 is lead bending type for long creepage distance (Gull-wing) for surface mount.

The PS9553L3 is lead bending type (Gull-wing) for surface mounting.

FEATURES

- Long creepage distance (8 mm MIN.: PS9553L1, PS9553L2)
- Peak output current (0.6 A MAX., 0.4 A MIN.)
- High speed switching (t_{PLH} , t_{PHL} = 0.65 μ s MAX.)
- High common mode transient immunity (CM_H , CM_L = ± 15 kV/ μ s MIN.)
- Ordering number of tape product: PS9553L2-E3: 1 000 pcs/reel
: PS9553L3-E3: 1 000 pcs/reel
- Pb-Free product

APPLICATIONS

- IGBT, Power MOS FET Gate Driver
- Industrial inverter
- IH (Induction Heating)

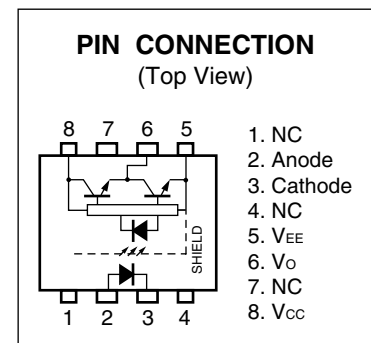

The information in this document is subject to change without notice. Before using this document, please confirm that this is the latest version.
Not all products and/or types are available in every country. Please check with an NEC Electronics sales representative for availability and additional information.

PACKAGE DIMENSIONS (UNIT: mm)

DIP Type

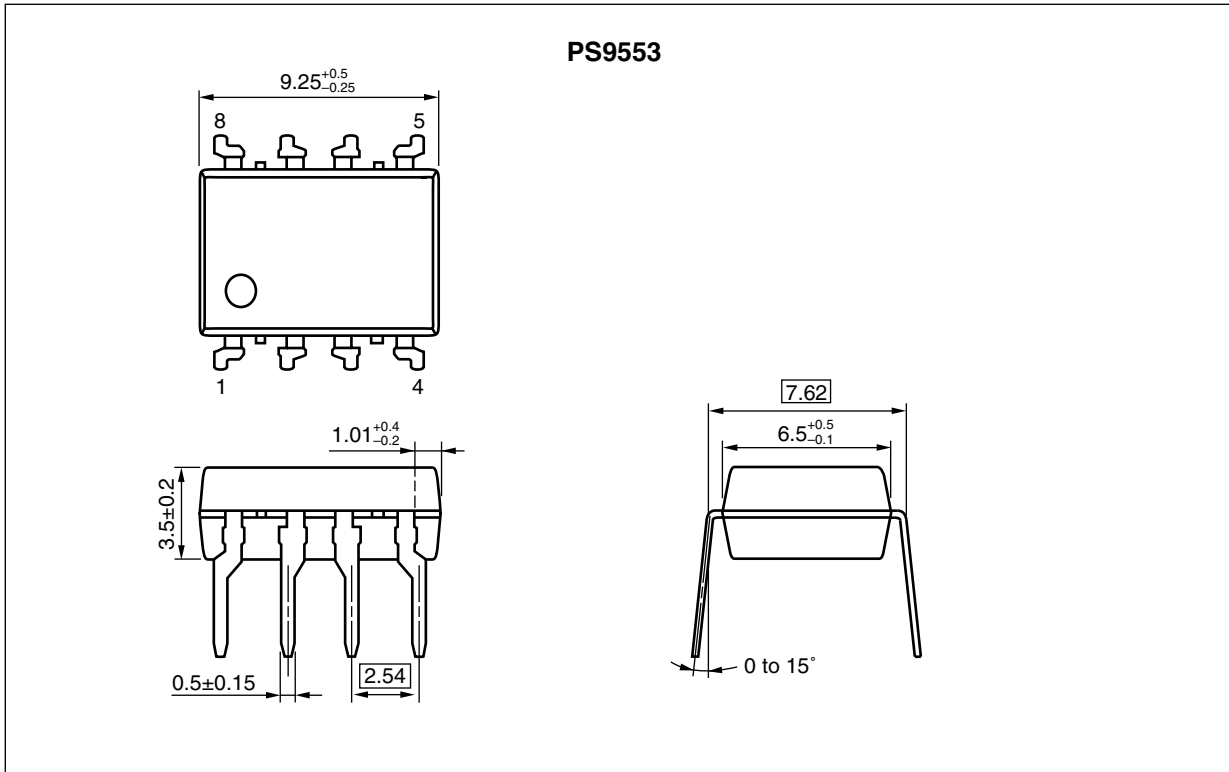

Lead Bending Type (Gull-wing) For Surface Mount

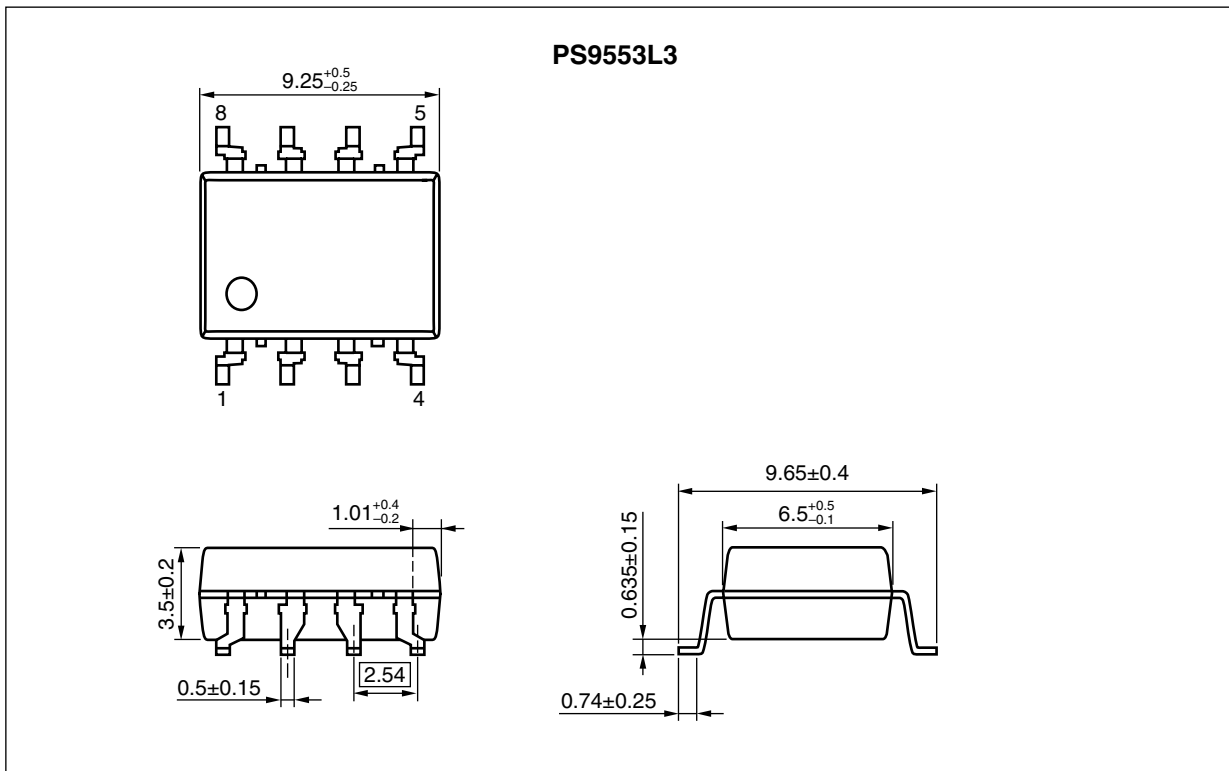

Lead Bending Type For Long Creepage Distance

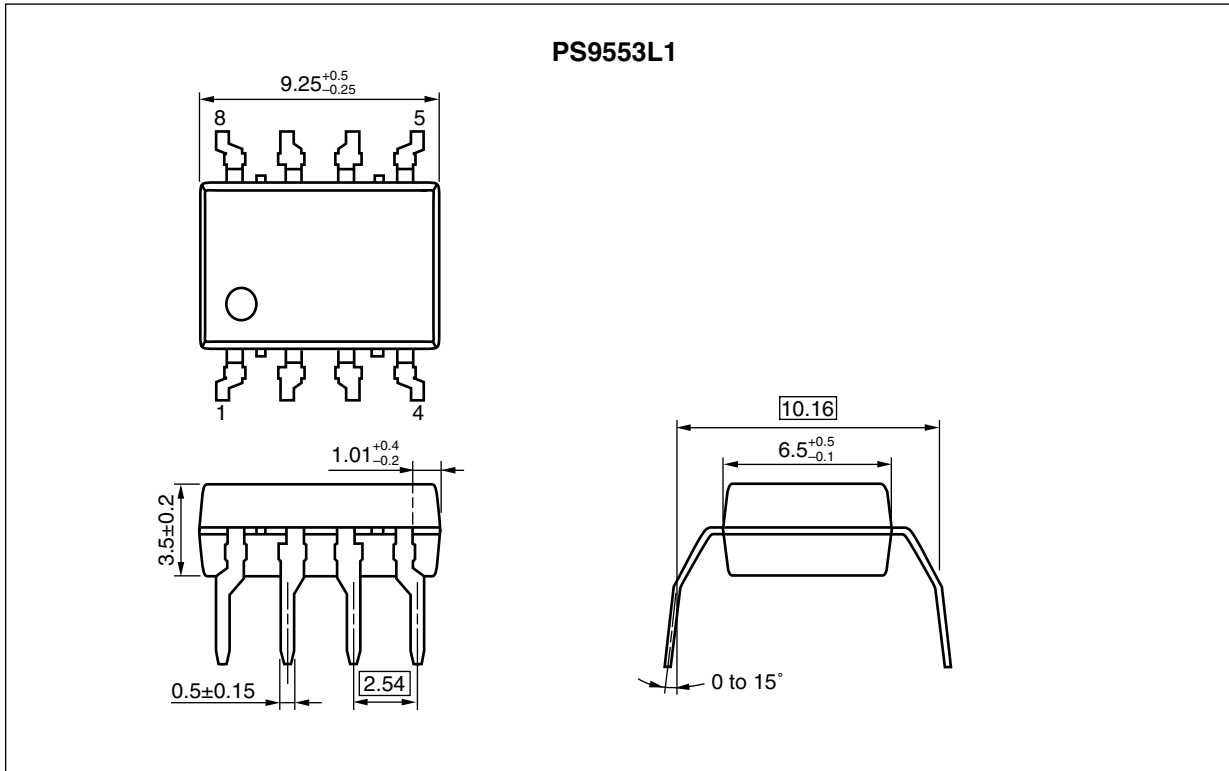

Lead Bending Type (Gull-wing) For Long Creepage Distance (Surface Mount)

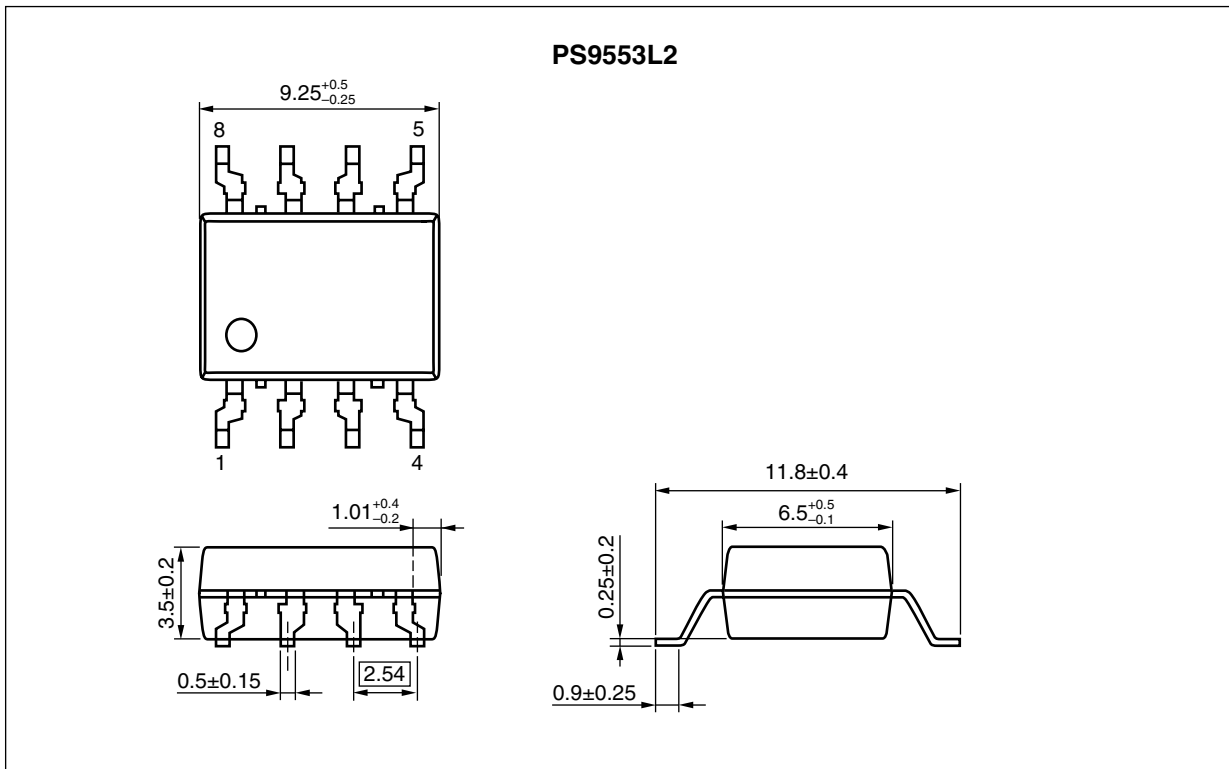

FUNCTIONAL DIAGRAM

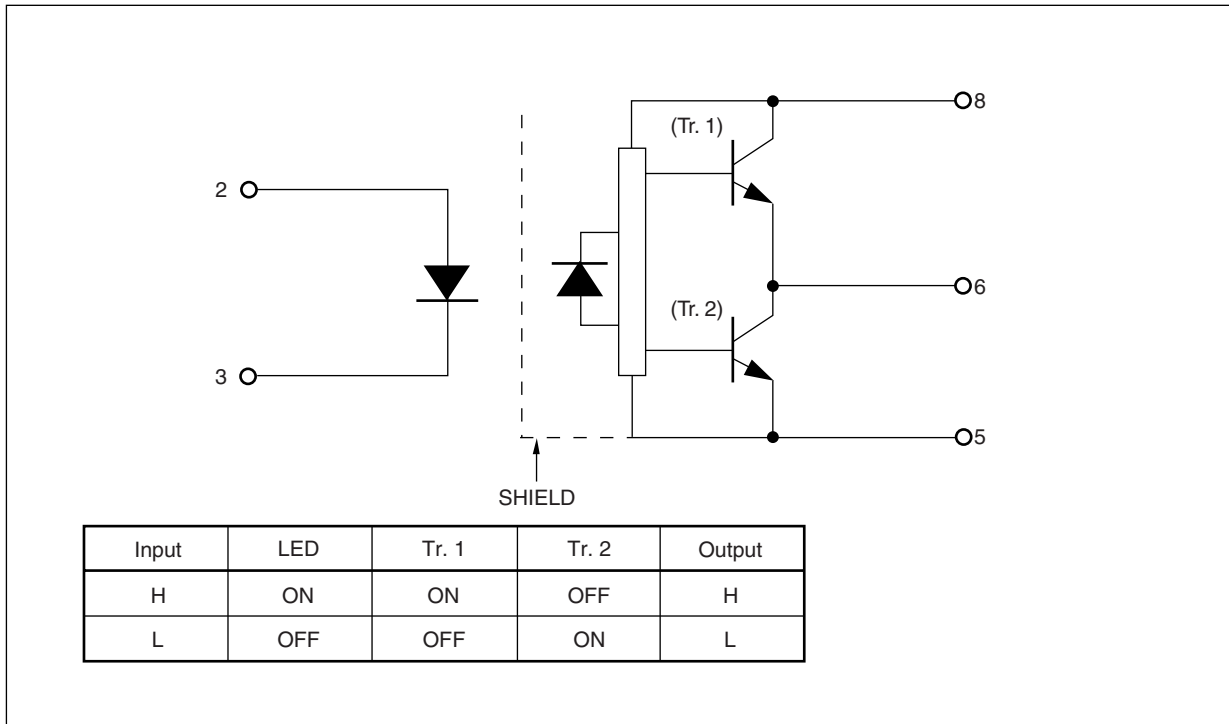

MARKING EXAMPLE

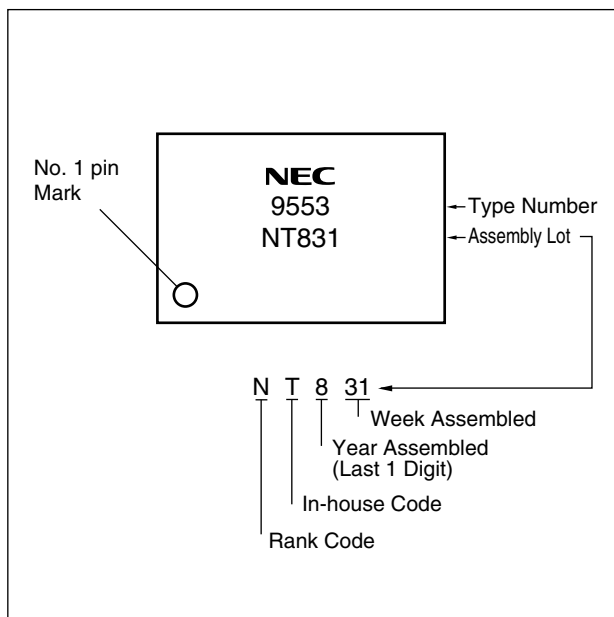

PHOTOCOUPLER CONSTRUCTION

Parameter	PS9553, PS9553L3	PS9553L1, PS9553L2
Air Distance (MIN.)	7 mm	8 mm
Outer Creepage Distance (MIN.)	7 mm	8 mm
Isolation Distance (MIN.)	0.4 mm	0.4 mm

ABSOLUTE MAXIMUM RATINGS (T_A = 25°C, unless otherwise specified)

Parameter		Symbol	Ratings	Unit
Diode	Forward Current	I _F	25	mA
	Peak Transient Forward Current (Pulse Width < 1 μs)	I _{F (TRAN)}	1.0	A
	Reverse Voltage	V _R	5	V
	Power Dissipation ^{*1}	P _D	45	mW
Detector	High Level Peak Output Current ^{*2}	I _{OH (PEAK)}	0.6	A
	Low Level Peak Output Current ^{*2}	I _{OL (PEAK)}	0.6	A
	Supply Voltage	(V _{CC} - V _{EE})	0 to 35	V
	Output Voltage	V _O	0 to V _{CC}	V
	Power Dissipation ^{*3}	P _C	250	mW
Isolation Voltage ^{*4}		BV	5 000	Vr.m.s.
Operating Frequency ^{*5}		f	25	kHz
Operating Ambient Temperature		T _A	-40 to +100	°C
Storage Temperature		T _{stg}	-55 to +125	°C

*1 Reduced to 1.6 mW/°C at T_A = 85°C or more.

*2 Maximum pulse width = 10 μs, Maximum duty cycle = 0.2%

*3 Reduced to 5.5 mW/°C at T_A = 75°C or more.

*4 AC voltage for 1 minute at T_A = 25°C, RH = 60% between input and output.

Pins 1-4 shorted together, 5-8 shorted together.

*5 I_{OH (PEAK)} ≤ 0.4 A (≤ 2.0 μs), I_{OL (PEAK)} ≤ 0.4 A (≤ 2.0 μs)

RECOMMENDED OPERATING CONDITIONS

Parameter	Symbol	MIN.	TYP.	MAX.	Unit
Supply Voltage	(V _{CC} - V _{EE})	10		30	V
Forward Current (ON)	I _{F (ON)}	8		12	mA
Forward Voltage (OFF)	V _{F (OFF)}	-2		0.8	V
Operating Ambient Temperature	T _A	-40		100	°C

ELECTRICAL CHARACTERISTICS ($T_A = -40$ to $+100^\circ\text{C}$, $V_{CC} = 10$ to 30 V, $I_F(\text{ON}) = 8$ to 12 mA, $V_F(\text{OFF}) = -2$ to 0.8 V, $V_{EE} = \text{GND}$, unless otherwise specified)

Parameter		Symbol	Conditions	MIN.	TYP.*1	MAX.	Unit
Diode	Forward Voltage	V_F	$I_F = 10$ mA, $T_A = 25^\circ\text{C}$	1.2	1.56	1.9	V
	Reverse Current	I_R	$V_R = 3$ V, $T_A = 25^\circ\text{C}$			10	μA
Detector	High Level Output Current	I_{OH}	$V_O = (V_{CC} - 4 \text{ V})^{*2}$	0.2			A
			$V_O = (V_{CC} - 10 \text{ V})^{*3}$	0.4	0.5		
	Low Level Output Current	I_{OL}	$V_O = (V_{EE} + 2.5 \text{ V})^{*2}$	0.2	0.4		A
			$V_O = (V_{EE} + 10 \text{ V})^{*3}$	0.4	0.5		
	High Level Output Voltage	V_{OH}	$I_O = -100$ mA ^{*4}	$V_{CC} - 4.0$	$V_{CC} - 1.8$		V
	Low Level Output Voltage	V_{OL}	$I_O = 100$ mA		0.4	1.0	V
	High Level Supply Current	I_{CCH}	$V_O = \text{open}$, $I_F = 8$ to 12 mA		0.7	3.0	mA
	Low Level Supply Current	I_{CCL}	$V_O = \text{open}$, $V_F = -2$ to $+0.8$ V		1.2	3.0	mA
Coupled	Threshold Input Current (L → H)	I_{FLH}	$I_O = 0$ mA, $V_O > 5$ V			5.0	mA
	Threshold Input Voltage (H → L)	V_{FHL}	$I_O = 0$ mA, $V_O < 5$ V	0.8			V
	Isolation Capacitance	C_{I-O}	$f = 1$ MHz, $V_F = 0$ V, $T_A = 25^\circ\text{C}$		60		pF

*1 Typical values at $T_A = 25^\circ\text{C}$, $V_{CC} - V_{EE} = 30$ V.

*2 Maximum pulse width = $50 \mu\text{s}$, Maximum duty cycle = 0.5%.

*3 Maximum pulse width = $10 \mu\text{s}$, Maximum duty cycle = 0.2%

*4 V_{OH} is measured with the DC load current in this testing.

SWITCHING CHARACTERISTICS ($T_A = -40$ to $+100^\circ\text{C}$, $V_{CC} = 10$ to 30 V, $I_F(\text{ON}) = 8$ to 12 mA, $V_F(\text{OFF}) = -2$ to 0.8 V, $V_{EE} = \text{GND}$, unless otherwise specified)

Parameter	Symbol	Conditions	MIN.	TYP.*1	MAX.	Unit
Propagation Delay Time (L → H)	t_{PLH}	$I_F = 10$ mA, $R_g = 47 \Omega$, $C_g = 3$ nF, $f = 10$ kHz, Duty Cycle = 50%*2	0.05	0.2	0.65	μs
Propagation Delay Time (H → L)	t_{PHL}		0.05	0.2	0.65	μs
Pulse Width Distortion (PWD)	$ t_{PHL} - t_{PLH} $		-0.5		0.5	μs
Propagation Delay Time (Difference Between Any Two Products)	$t_{PHL} - t_{PLH}$			50		ns
Rise Time	t_r			50		ns
Fall Time	t_f					
Common Mode Transient Immunity at High Level Output*3	$ CM_H $	$T_A = 25^\circ\text{C}$, $I_F = 10$ mA, $V_{CC} = 30$ V, $V_{O(\text{MIN.})} = 26$ V, $V_{CM} = 1.5$ kV	15			kV/ μs
Common Mode Transient Immunity at Low Level Output*3	$ CM_L $	$T_A = 25^\circ\text{C}$, $I_F = 0$ mA, $V_{CC} = 30$ V, $V_{O(\text{MAX.})} = 1$ V, $V_{CM} = 1.5$ kV	15			kV/ μs

*1 Typical values at $T_A = 25^\circ\text{C}$, $V_{CC} - V_{EE} = 30$ V.

*2 This load condition is equivalent to the IGBT load at 1 200 V/25 A.

*3 Connect pin 1 and pin 4 to the LED common.

TEST CIRCUIT

Fig. 1 I_{OH} Test Circuit

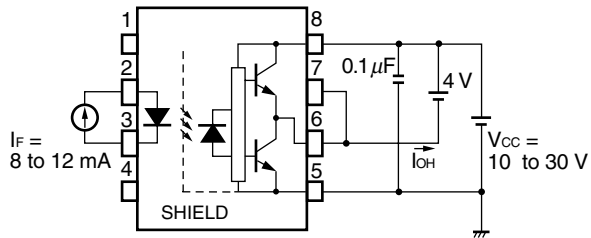

Fig. 2 I_{oL} Test Circuit

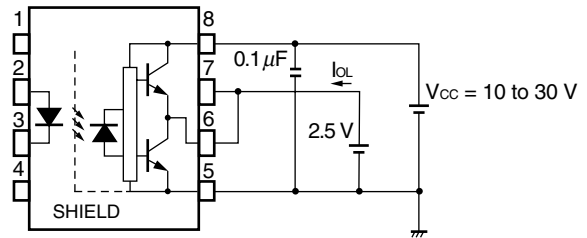

Fig. 3 V_{oH} Test Circuit

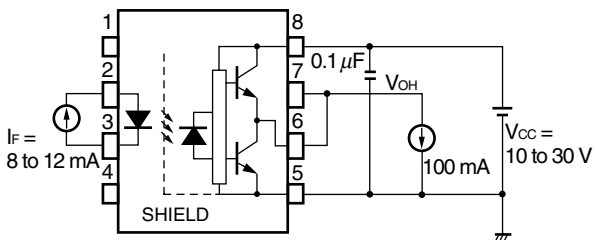

Fig. 4 V_{oL} Test Circuit

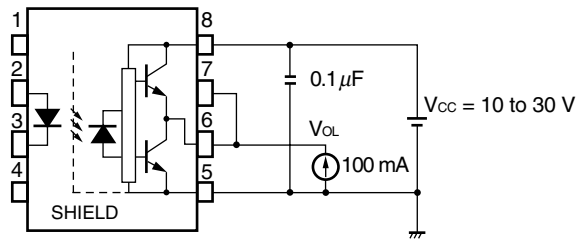

Fig. 5 I_{FLH} Test Circuit

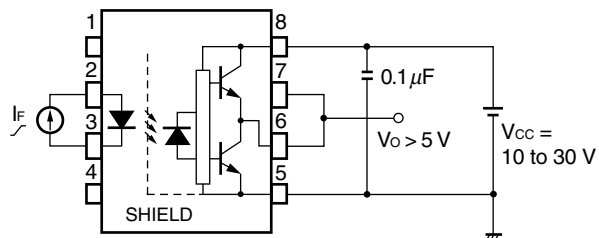

Fig. 6 t_{PLH} , t_{PHL} , t_r , t_f Test Circuit and Wave Forms

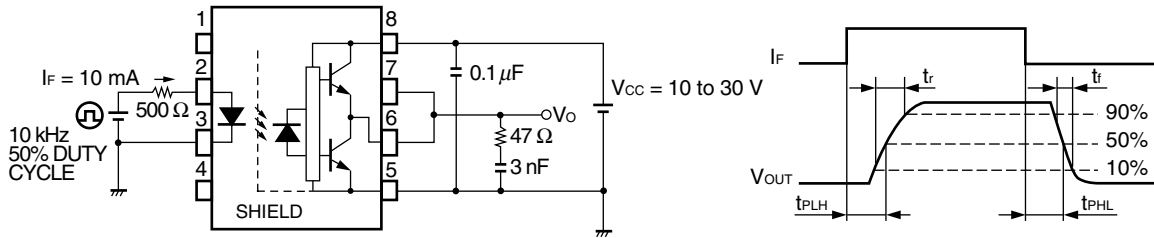
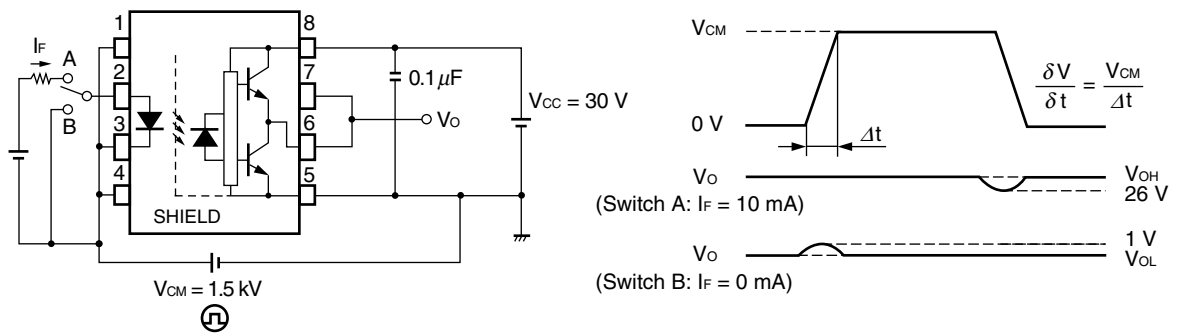

Fig. 7 CMR Test Circuit and Wave Forms



Remark CMR Test : Connect pin 1 and pin 4 to the LED common.

TAPING SPECIFICATIONS (UNIT: mm)

Outline and Dimensions (Tape)

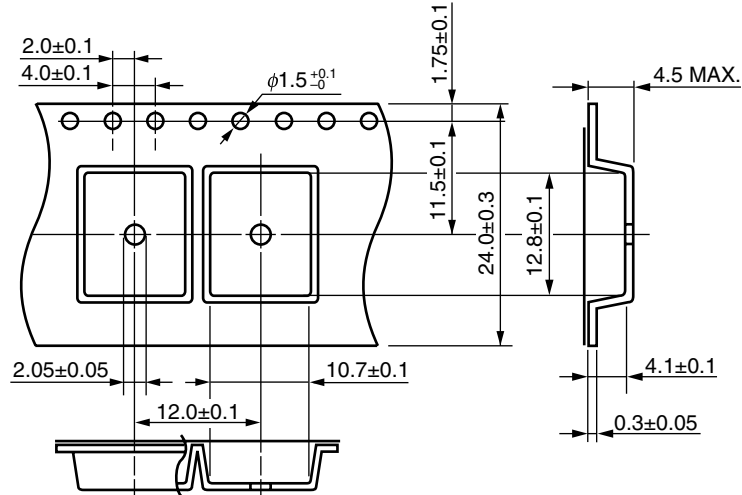

Tape Direction

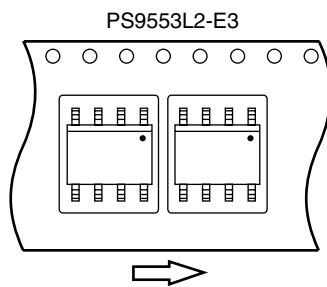

Outline and Dimensions (Reel)

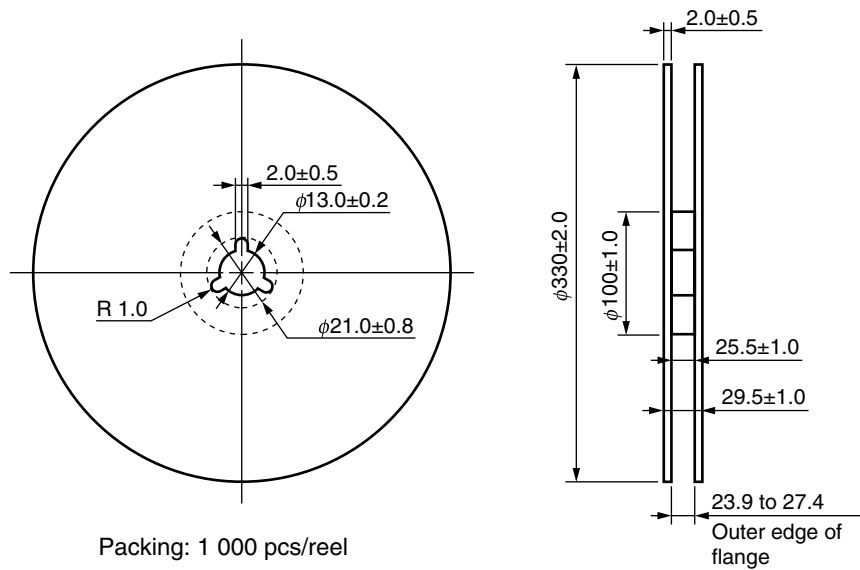

Outline and Dimensions (Tape)

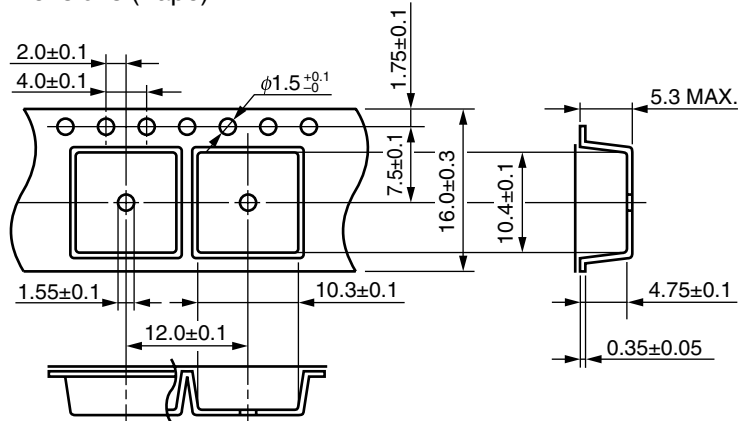

Tape Direction

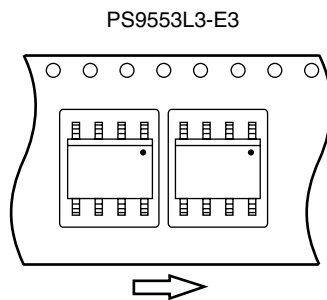

Outline and Dimensions (Reel)

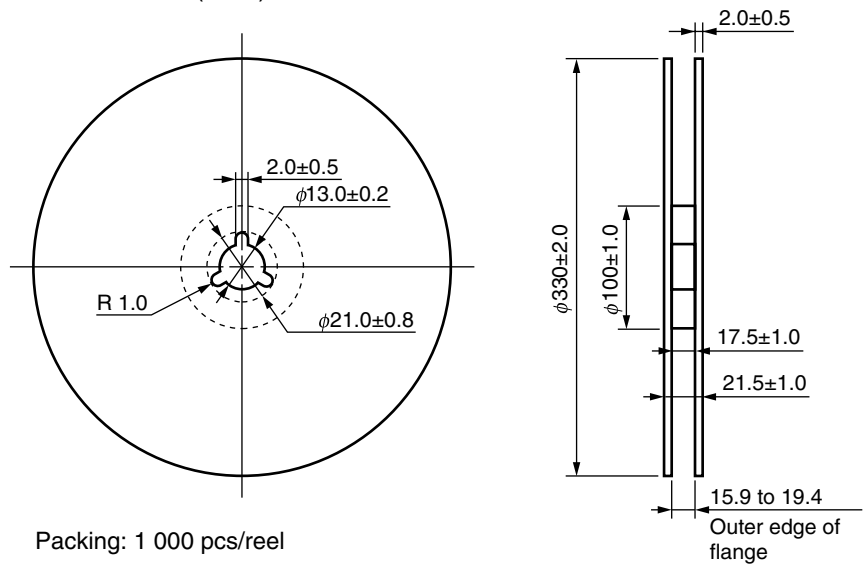

RECOMMENDED MOUNT PAD DIMENSIONS (UNIT: mm)

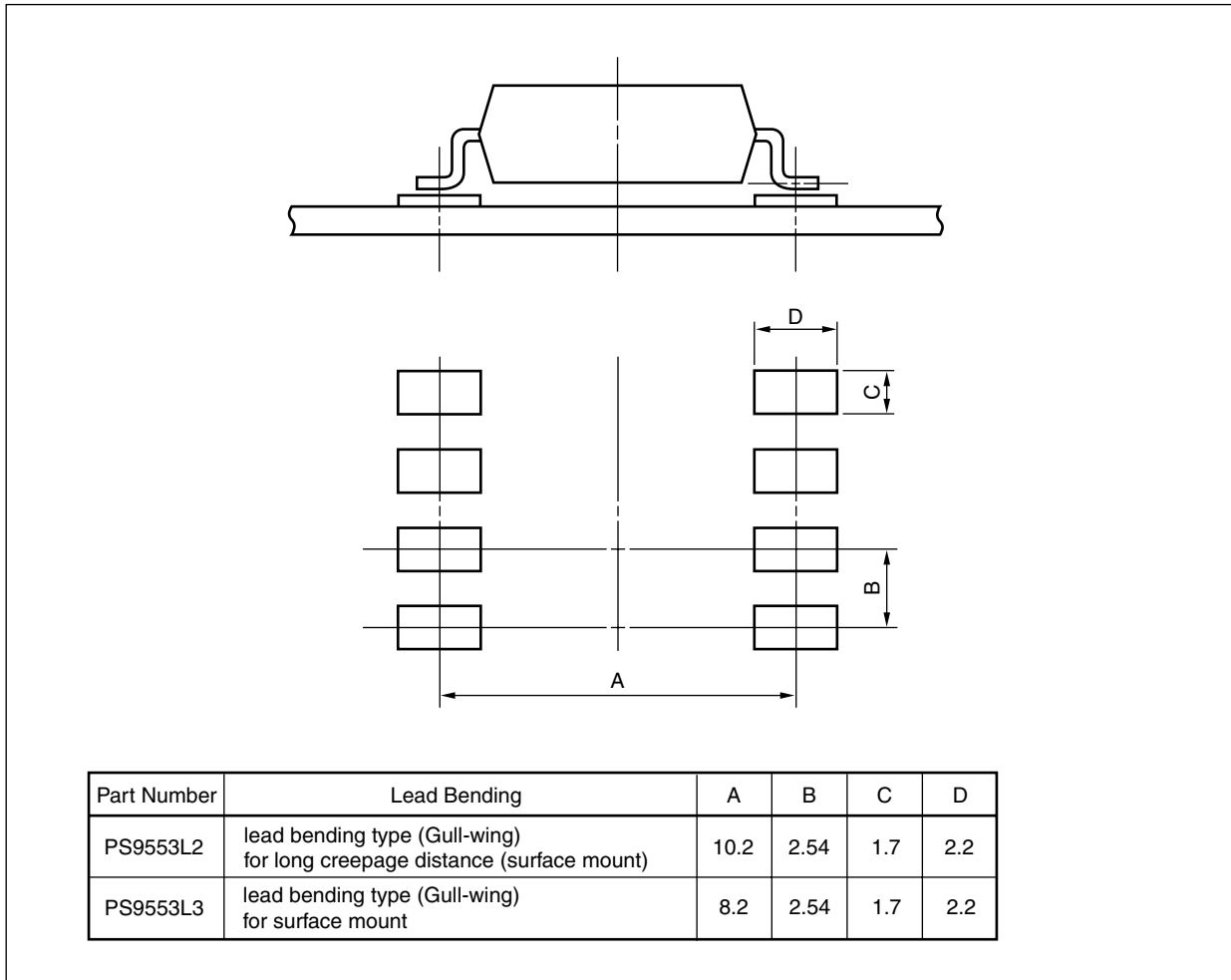

NOTES ON HANDLING

Cautions regarding noise

Be aware that when voltage is applied suddenly between the photocoupler's input and output at startup, the output transistor may enter the on state, even if the voltage is within the absolute maximum ratings.

USAGE CAUTIONS

1. This product is weak for static electricity by designed with high-speed integrated circuit so protect against static electricity when handling.
2. Board designing
 - (1) By-pass capacitor of more than 0.1 μF is used between V_{CC} and GND near device. Also, ensure that the distance between the leads of the photocoupler and capacitor is no more than 10 mm.
 - (2) In order to avoid malfunctions and characteristics degradation, IGBT collector or emitter traces should not be closed to the LED input.
3. Make sure the rise/fall time of the forward current is 0.5 μs or less.
4. In order to avoid malfunctions, make sure the rise/fall slope of the supply voltage is 3 V/ μs or less.
5. Avoid storage at a high temperature and high humidity.

• **The information in this document is current as of July, 2008. The information is subject to change without notice. For actual design-in, refer to the latest publications of NEC Electronics data sheets or data books, etc., for the most up-to-date specifications of NEC Electronics products. Not all products and/or types are available in every country. Please check with an NEC Electronics sales representative for availability and additional information.**

• No part of this document may be copied or reproduced in any form or by any means without the prior written consent of NEC Electronics. NEC Electronics assumes no responsibility for any errors that may appear in this document.

• NEC Electronics does not assume any liability for infringement of patents, copyrights or other intellectual property rights of third parties by or arising from the use of NEC Electronics products listed in this document or any other liability arising from the use of such products. No license, express, implied or otherwise, is granted under any patents, copyrights or other intellectual property rights of NEC Electronics or others.

• Descriptions of circuits, software and other related information in this document are provided for illustrative purposes in semiconductor product operation and application examples. The incorporation of these circuits, software and information in the design of a customer's equipment shall be done under the full responsibility of the customer. NEC Electronics assumes no responsibility for any losses incurred by customers or third parties arising from the use of these circuits, software and information.

• While NEC Electronics endeavors to enhance the quality, reliability and safety of NEC Electronics products, customers agree and acknowledge that the possibility of defects thereof cannot be eliminated entirely. To minimize risks of damage to property or injury (including death) to persons arising from defects in NEC Electronics products, customers must incorporate sufficient safety measures in their design, such as redundancy, fire-containment and anti-failure features.

• NEC Electronics products are classified into the following three quality grades: "Standard", "Special" and "Specific".

The "Specific" quality grade applies only to NEC Electronics products developed based on a customer-designated "quality assurance program" for a specific application. The recommended applications of an NEC Electronics product depend on its quality grade, as indicated below. Customers must check the quality grade of each NEC Electronics product before using it in a particular application.

"Standard": Computers, office equipment, communications equipment, test and measurement equipment, audio and visual equipment, home electronic appliances, machine tools, personal electronic equipment and industrial robots.

"Special": Transportation equipment (automobiles, trains, ships, etc.), traffic control systems, anti-disaster systems, anti-crime systems, safety equipment and medical equipment (not specifically designed for life support).

"Specific": Aircraft, aerospace equipment, submersible repeaters, nuclear reactor control systems, life support systems and medical equipment for life support, etc.

The quality grade of NEC Electronics products is "Standard" unless otherwise expressly specified in NEC Electronics data sheets or data books, etc. If customers wish to use NEC Electronics products in applications not intended by NEC Electronics, they must contact an NEC Electronics sales representative in advance to determine NEC Electronics' willingness to support a given application.

(Note)

(1) "NEC Electronics" as used in this statement means NEC Electronics Corporation and also includes its majority-owned subsidiaries.

(2) "NEC Electronics products" means any product developed or manufactured by or for NEC Electronics (as defined above).

Caution	GaAs Products	<p>This product uses gallium arsenide (GaAs). GaAs vapor and powder are hazardous to human health if inhaled or ingested, so please observe the following points.</p> <ul style="list-style-type: none">• Follow related laws and ordinances when disposing of the product. If there are no applicable laws and/or ordinances, dispose of the product as recommended below.<ol style="list-style-type: none">1. Commission a disposal company able to (with a license to) collect, transport and dispose of materials that contain arsenic and other such industrial waste materials.2. Exclude the product from general industrial waste and household garbage, and ensure that the product is controlled (as industrial waste subject to special control) up until final disposal.• Do not burn, destroy, cut, crush, or chemically dissolve the product.• Do not lick the product or in any way allow it to enter the mouth.
----------------	---------------	--